

NOTES:

1. Collimation bolts: (3) 1/4-20 x 3" flat head bolts, with washer and wingnut.
2. Center pivot: 1/4-20 x 1" bolt, capped with acorn nut.
3. Mirror supported by three caulk blobs on mirror plate, and radially by caulk between mirror edge and brackets.
4. Brackets secured by small wood screws.
5. Acorn nut seats into and pivots on 5/8" x 1/2" set screw in mirror plate.

8-INCH MIRROR CELL ASSEMBLY

QTY

UNLESS OTHERWISE SPECIFIED
DIMENSIONS ARE IN INCHES

TOLERANCES ARE:
FRACTIONS DECIMALS ANGLES
+ .XX+ .XX + 1
.XXX+.XXX

MATERIAL various

FINISH --

DO NOT SCALE DRAWING

CAD GENERATED DRAWING,
REPORT ANY SHOP CHANGES

APPROVALS	DATE
DRAWN	
CHECKED	
RESP ENG	
MFG ENG	
QUAL ENG	

8" DOBSONIAN TELESCOPE PROJECT 2004



SIZE A	DWG. NO.	REV.
SCALE	CAD FILE:	SHEET OF

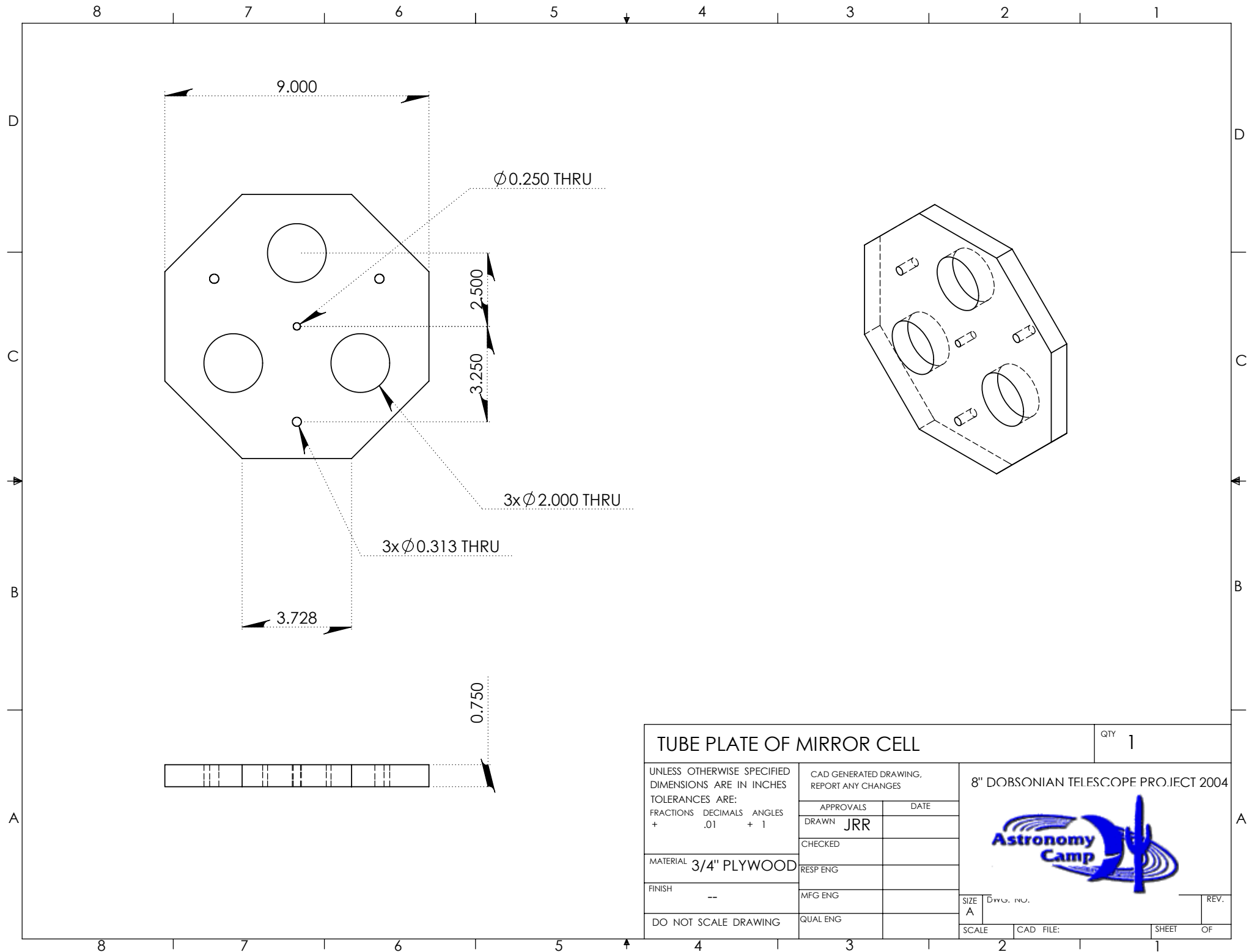

TUBE PLATE OF MIRROR CELL			QTY 1
UNLESS OTHERWISE SPECIFIED DIMENSIONS ARE IN INCHES TOLERANCES ARE: FRACTIONS DECIMALS ANGLES + .01 + 1	CAD GENERATED DRAWING, REPORT ANY CHANGES		8" DOBSONIAN TELESCOPE PROJECT 2004 
	APPROVALS	DATE	
MATERIAL 3/4" PLYWOOD	DRAWN JRR		REV.
FINISH --	CHECKED		
DO NOT SCALE DRAWING	RESP ENG		
	MFG ENG		
	QUAL ENG		
SCALE	CAD FILE:	SHEET	OF

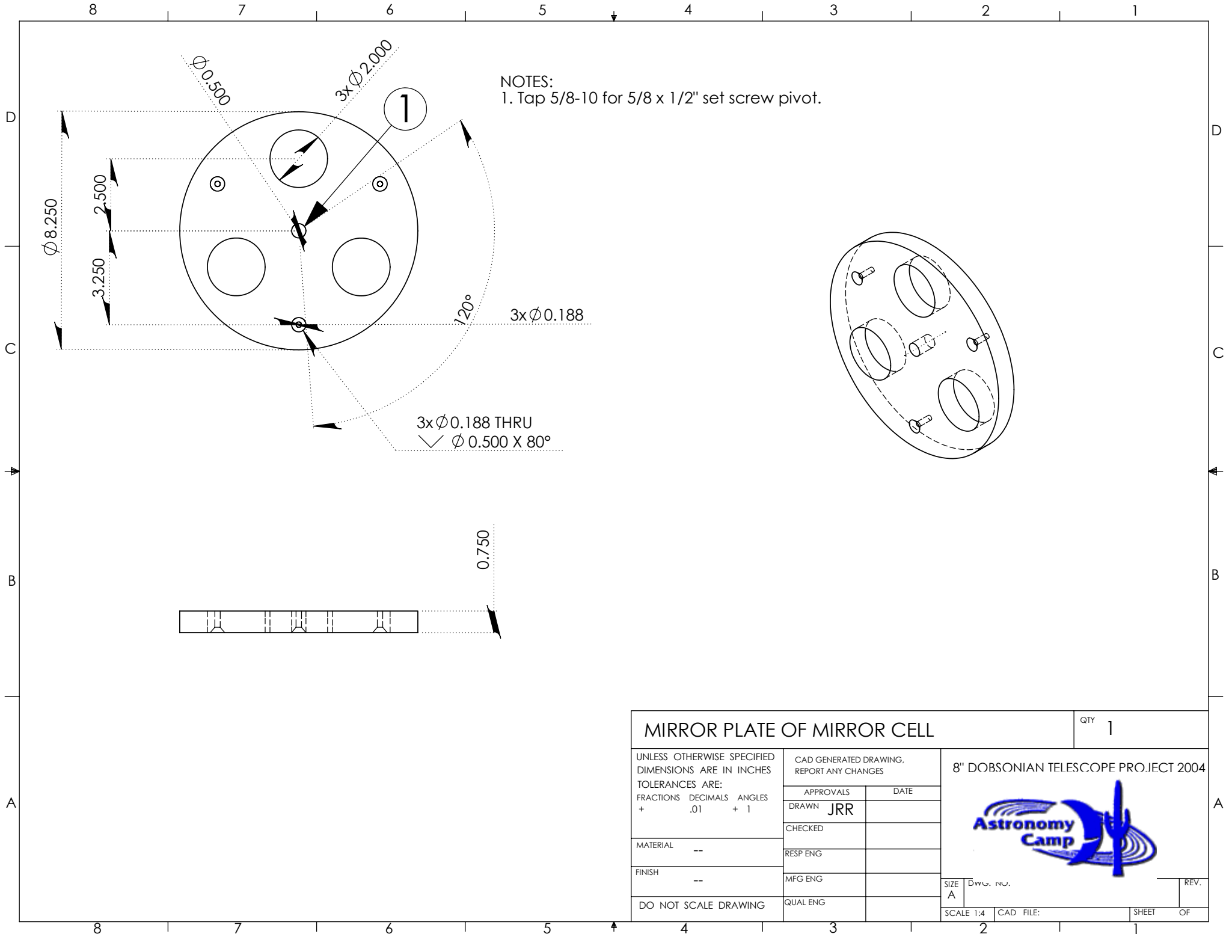

NOTES:
 1. Tap 5/8-10 for 5/8 x 1/2" set screw pivot.

3x ϕ 0.188

3x ϕ 0.188 THRU
 \sphericalangle ϕ 0.500 X 80°

0.750

MIRROR PLATE OF MIRROR CELL				QTY 1	
UNLESS OTHERWISE SPECIFIED DIMENSIONS ARE IN INCHES TOLERANCES ARE: FRACTIONS DECIMALS ANGLES + .01 + 1		CAD GENERATED DRAWING. REPORT ANY CHANGES		8" DOBSONIAN TELESCOPE PROJECT 2004	
		APPROVALS	DATE		
MATERIAL		DRAWN	JRR		
FINISH		CHECKED			
DO NOT SCALE DRAWING		RESP ENG			
		MFG ENG			
		QUAL ENG		SIZE A	DWG. NO.
				SCALE 1:4	CAD FILE:
				SHEET	OF

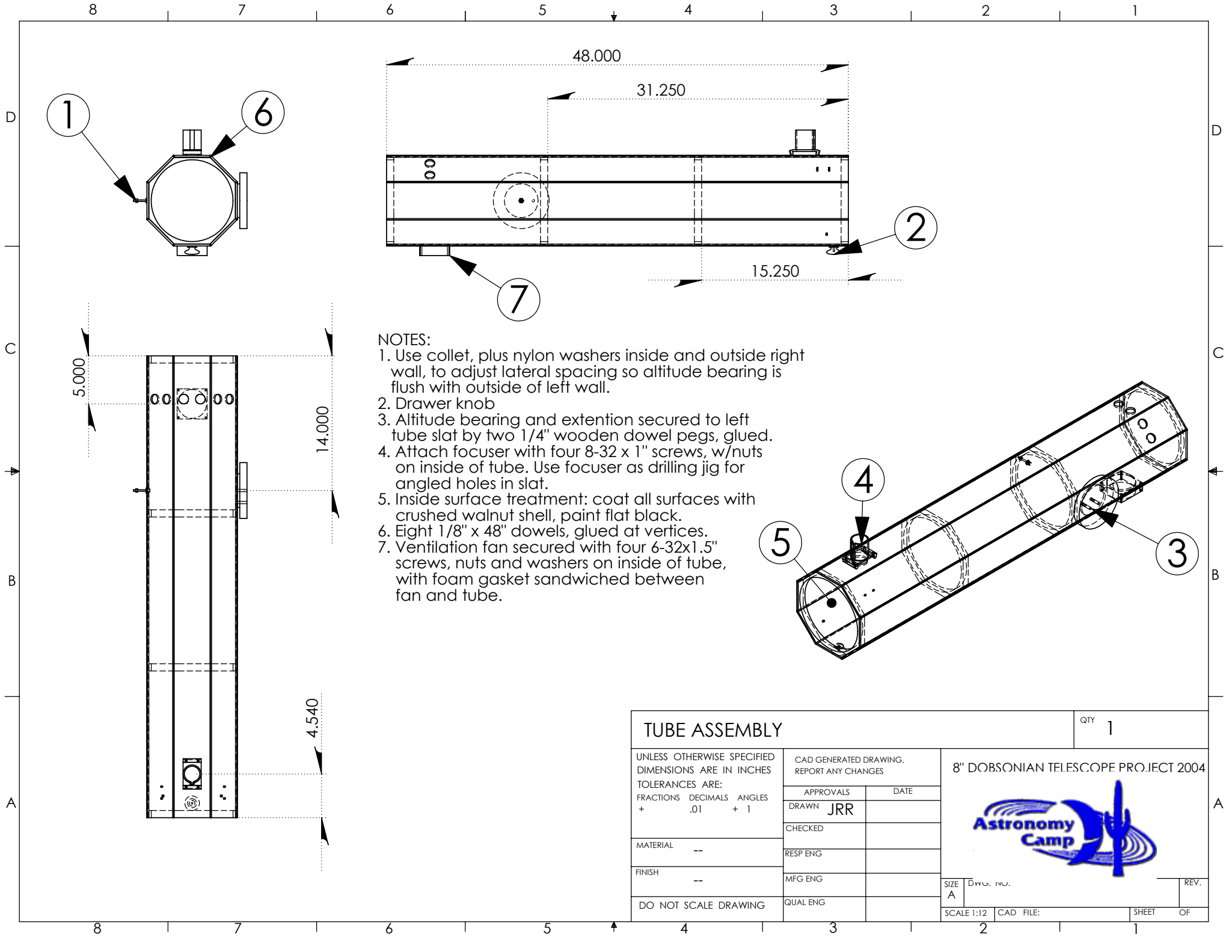

NOTES:

1. Use collet, plus nylon washers inside and outside right wall, to adjust lateral spacing so altitude bearing is flush with outside of left wall.
2. Drawer knob
3. Altitude bearing and extention secured to left tube slat by two 1/4" wooden dowel pegs, glued.
4. Attach focuser with four 8-32 x 1" screws, w/nuts on inside of tube. Use focuser as drilling jig for angled holes in slat.
5. Inside surface treatment: coat all surfaces with crushed walnut shell, paint flat black.
6. Eight 1/8" x 48" dowels, glued at vertices.
7. Ventilation fan secured with four 6-32x1.5" screws, nuts and washers on inside of tube, with foam gasket sandwiched between fan and tube.

TUBE ASSEMBLY

QTY 1

UNLESS OTHERWISE SPECIFIED
DIMENSIONS ARE IN INCHES
TOLERANCES ARE:
FRACTIONS DECIMALS ANGLES
+ .01 + 1

CAD GENERATED DRAWING,
REPORT ANY CHANGES

8" DOBSONIAN TELESCOPE PROJECT 2004

APPROVALS DATE

DRAWN JRR

CHECKED

RESP ENG

MFG ENG

QUAL ENG



SIZE A Dwg. NO.

REV.

SCALE 1:12 CAD FILE:

SHEET OF

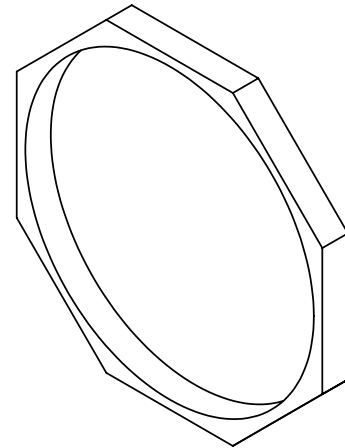
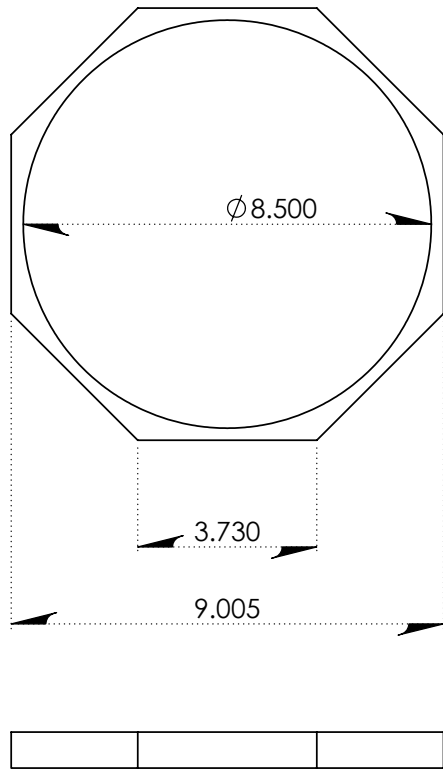

TUBE RING OF TUBE

QTY **4**

UNLESS OTHERWISE SPECIFIED
DIMENSIONS ARE IN INCHES
TOLERANCES ARE:
FRACTIONS DECIMALS ANGLES
+ .01 + 1

CAD GENERATED DRAWING.
REPORT ANY CHANGES

8" DOBSONIAN TELESCOPE PROJECT 2004

APPROVALS DATE

DRAWN **JRR**

CHECKED

RESP ENG

MFG ENG

QUAL ENG



MATERIAL **3/4" PLYWOOD**

FINISH --

DO NOT SCALE DRAWING

SIZE **A** DWG. NO.

REV.

SCALE 1:4 CAD FILE:

SHEET OF

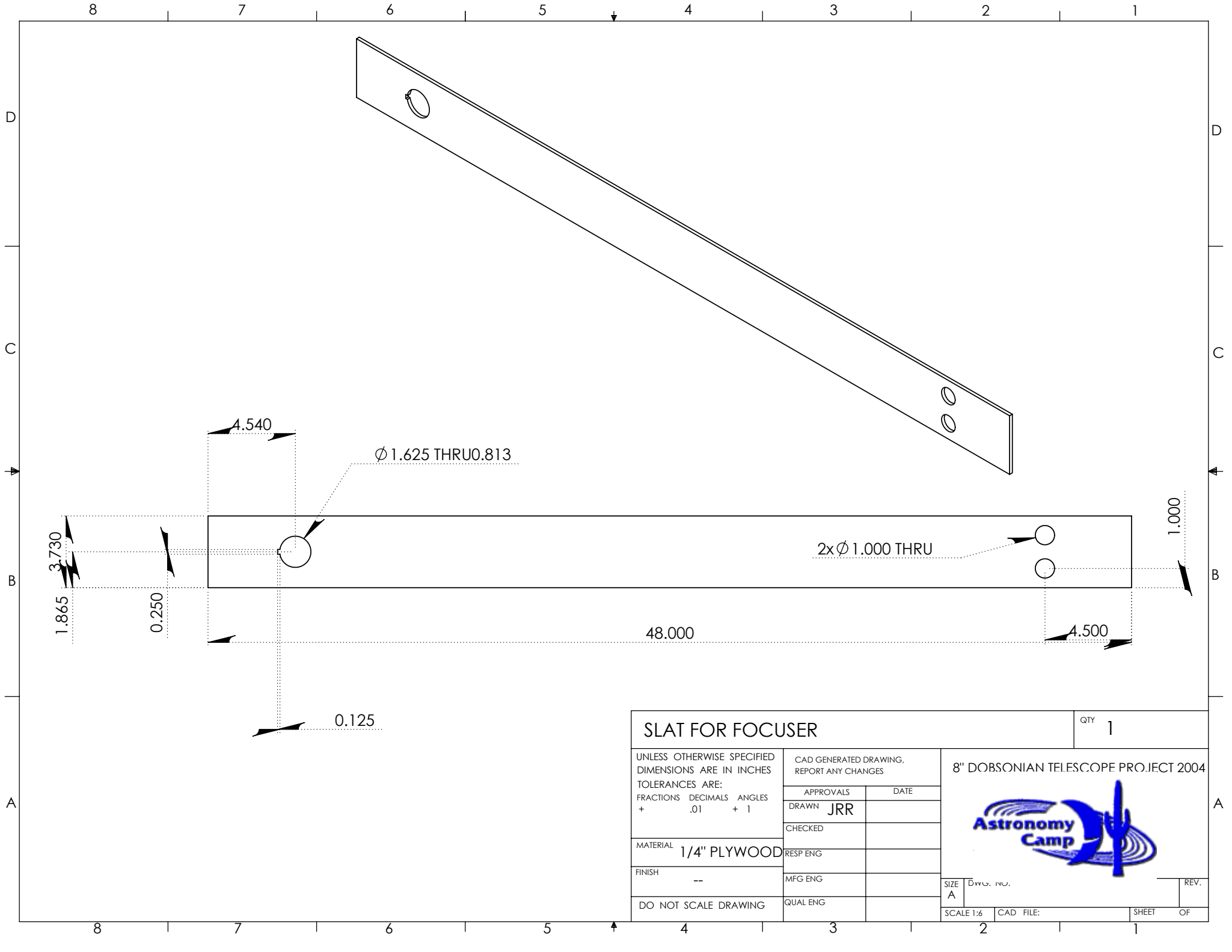

SLAT FOR FOCUSER			QTY 1	
UNLESS OTHERWISE SPECIFIED DIMENSIONS ARE IN INCHES		CAD GENERATED DRAWING. REPORT ANY CHANGES		8" DOBSONIAN TELESCOPE PROJECT 2004
TOLERANCES ARE:		APPROVALS		
FRACTIONS DECIMALS ANGLES		DATE		
+ .01 + 1		DRAWN JRR		
MATERIAL 1/4" PLYWOOD		CHECKED		
FINISH --		RESP ENG		
DO NOT SCALE DRAWING		MFG ENG		
		QUAL ENG		SIZE A
				DWG. NO.
				REV.
				SCALE 1:6
				CAD FILE:
				SHEET OF

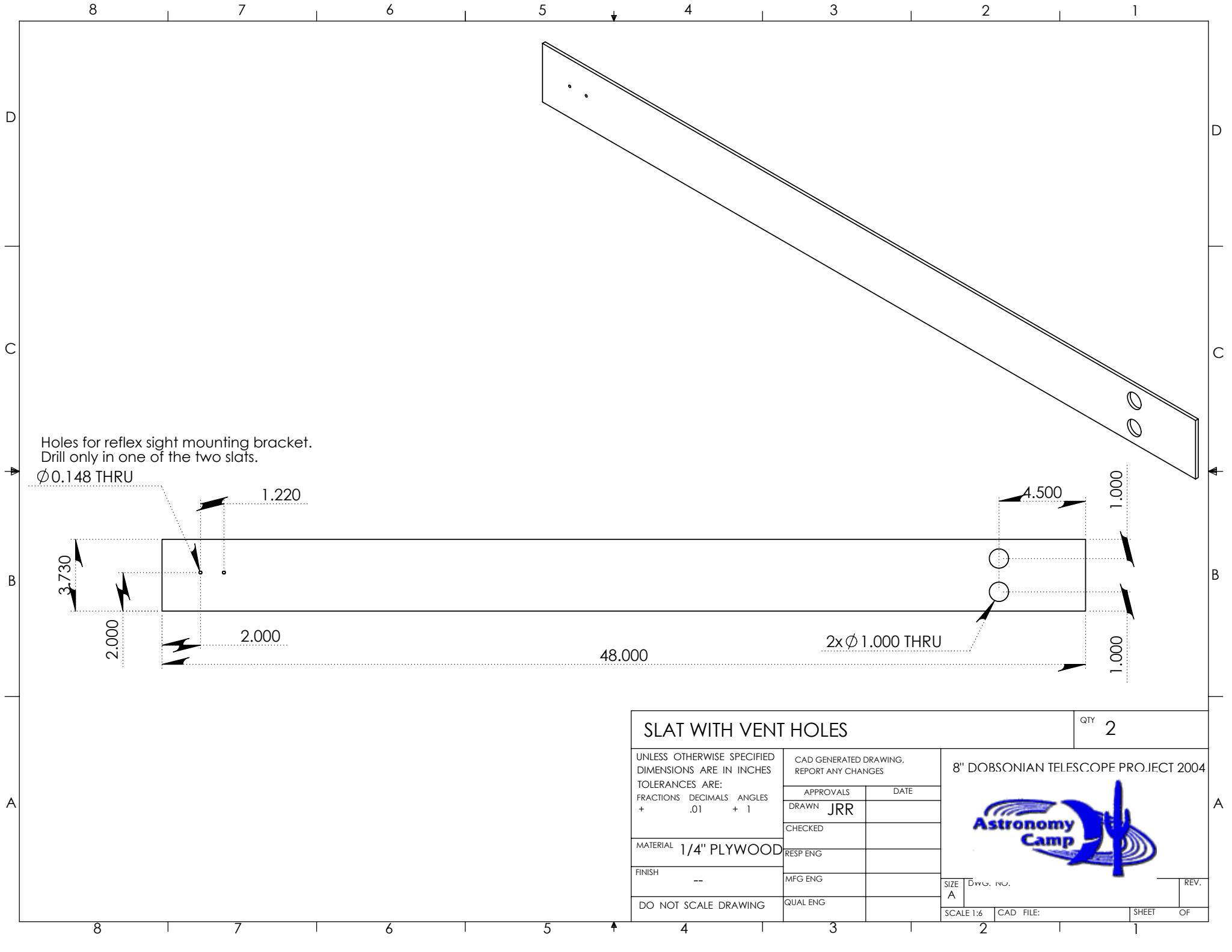

Holes for reflex sight mounting bracket.
Drill only in one of the two slats.
Ø0.148 THRU

SLAT WITH VENT HOLES				QTY 2	
UNLESS OTHERWISE SPECIFIED DIMENSIONS ARE IN INCHES TOLERANCES ARE: FRACTIONS DECIMALS ANGLES + .01 + 1		CAD GENERATED DRAWING. REPORT ANY CHANGES		8" DOBSONIAN TELESCOPE PROJECT 2004	
		APPROVALS	DATE		
MATERIAL 1/4" PLYWOOD		DRAWN JRR			
FINISH --		CHECKED			
DO NOT SCALE DRAWING		RESP ENG			
		MFG ENG			
		QUAL ENG		SIZE A	DWG. NO.
				SCALE 1:6	CAD FILE:
				SHEET	OF



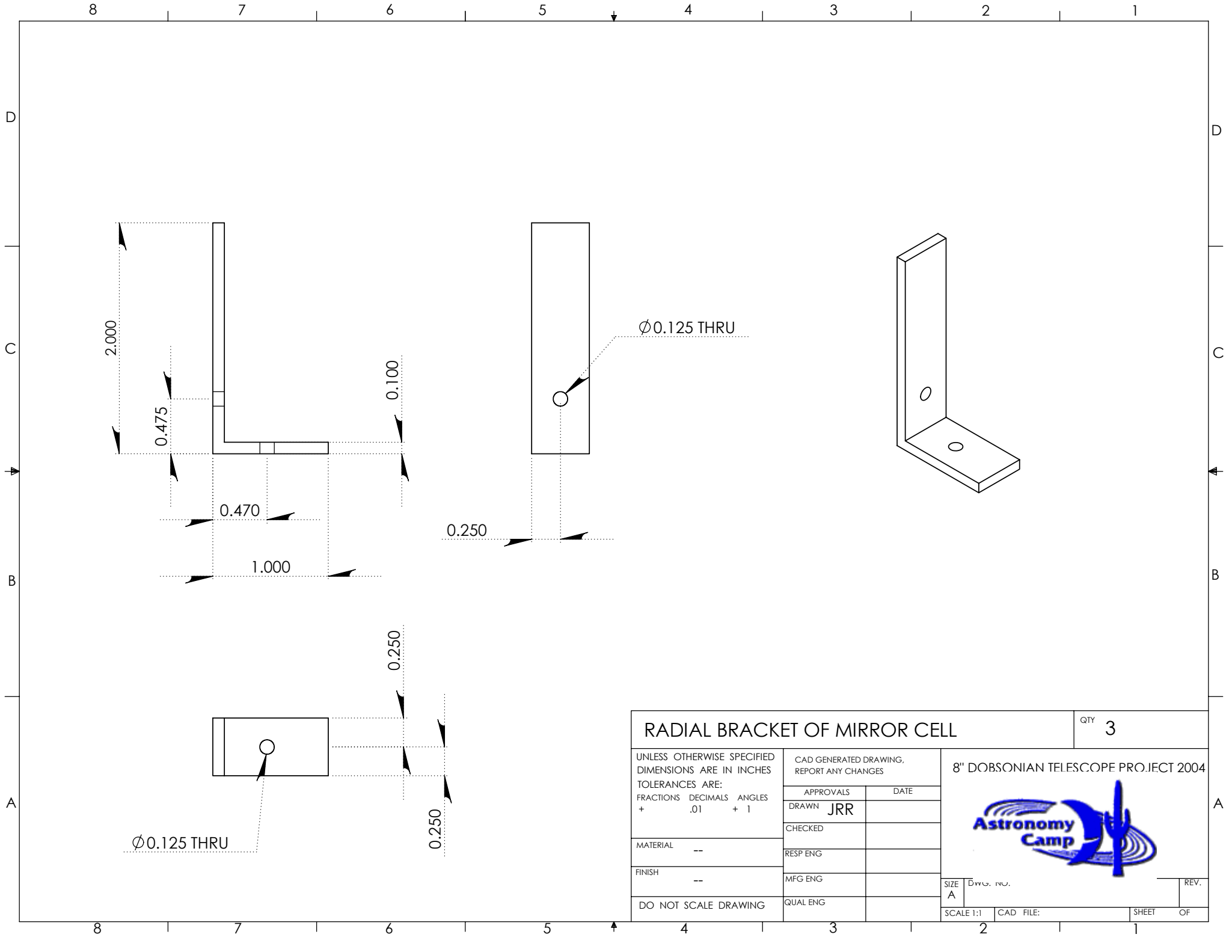

RADIAL BRACKET OF MIRROR CELL				QTY 3		
UNLESS OTHERWISE SPECIFIED DIMENSIONS ARE IN INCHES TOLERANCES ARE: FRACTIONS DECIMALS ANGLES + .01 + 1		CAD GENERATED DRAWING. REPORT ANY CHANGES		8" DOBSONIAN TELESCOPE PROJECT 2004		
		APPROVALS	DATE			
MATERIAL		DRAWN	JRR			
FINISH		CHECKED				
DO NOT SCALE DRAWING		RESP ENG				
		MFG ENG				
		QUAL ENG		SIZE	DWG. NO.	REV.
		SCALE 1:1	CAD FILE:	SHEET	OF	

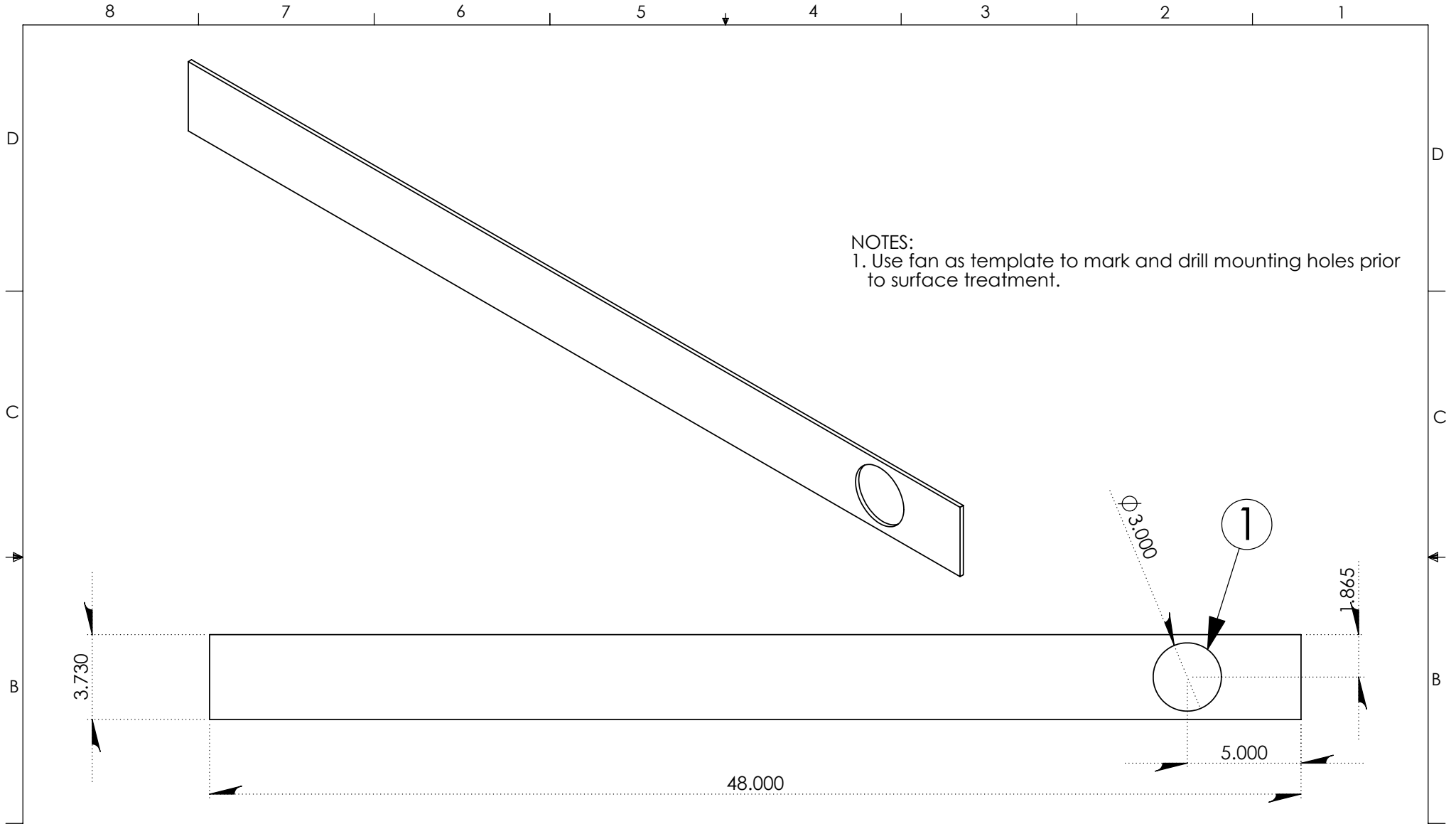

NOTES:
 1. Use fan as template to mark and drill mounting holes prior to surface treatment.

SLAT WITH HOLE FOR COOLING FAN			QTY	1
UNLESS OTHERWISE SPECIFIED DIMENSIONS ARE IN INCHES		CAD GENERATED DRAWING. REPORT ANY CHANGES		8" DOBSONIAN TELESCOPE PROJECT 2004
TOLERANCES ARE:		APPROVALS		
FRACTIONS	DECIMALS	ANGLES	DATE	
+	.01	+ 1		
MATERIAL 1/4" PLYWOOD		DRAWN JRR		
FINISH --		CHECKED		
DO NOT SCALE DRAWING		RESP ENG		
		MFG ENG		SIZE A
		QUAL ENG		DWG. NO.
				SCALE 1:6
				CAD FILE:
				SHEET OF

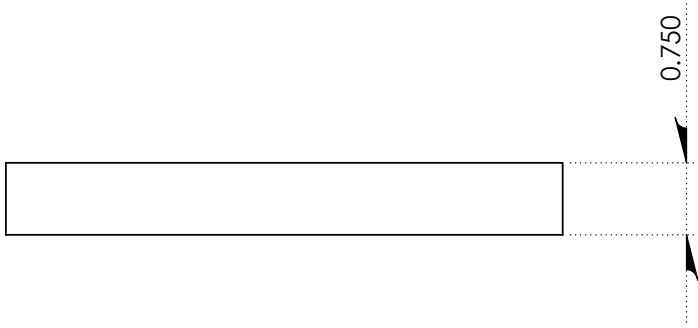
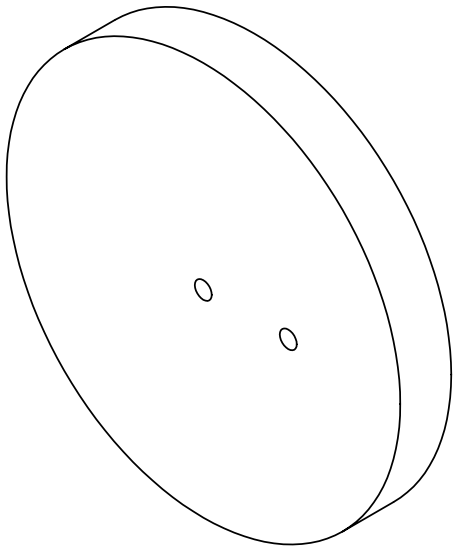
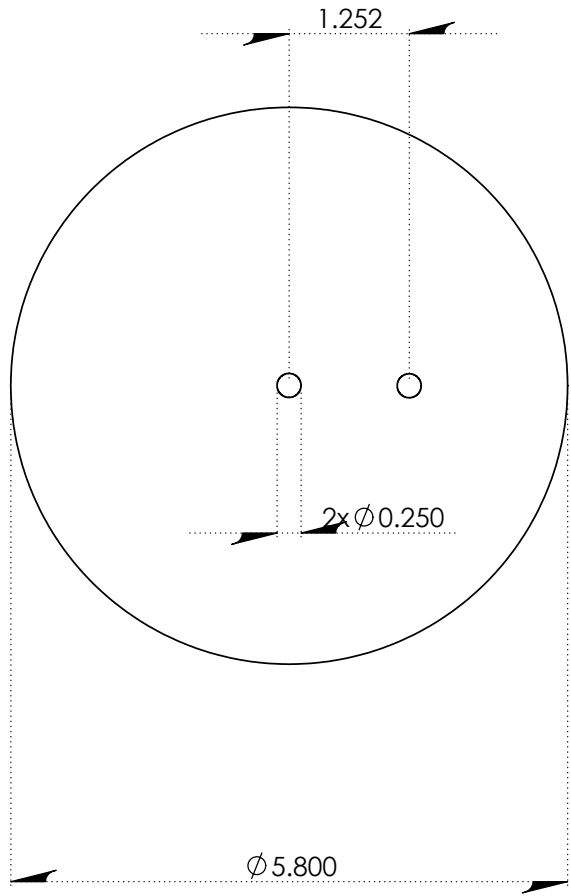

ALTITUDE BEARING				QTY 1	
UNLESS OTHERWISE SPECIFIED DIMENSIONS ARE IN INCHES TOLERANCES ARE: FRACTIONS DECIMALS ANGLES + .01 + 1		CAD GENERATED DRAWING. REPORT ANY CHANGES		8" DOBSONIAN TELESCOPE PROJECT 2004	
		APPROVALS	DATE		
MATERIAL 3/4" PLYWOOD		DRAWN JRR			
FINISH --		CHECKED			
DO NOT SCALE DRAWING		RESP ENG			
		MFG ENG			
		QUAL ENG		SIZE A	DWG. NO.
		SCALE 1:2 CAD FILE:		SHEET	OF



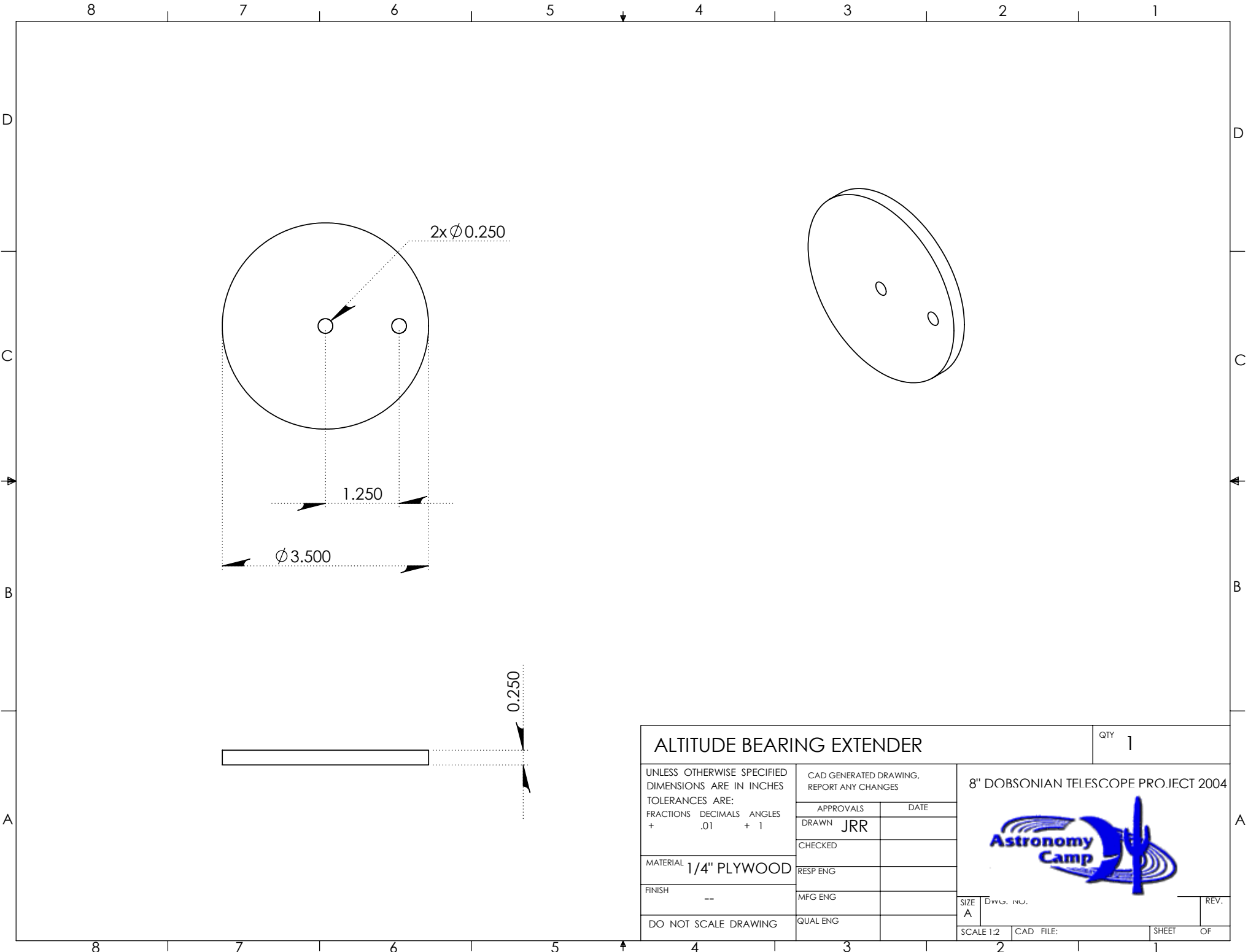

ALTITUDE BEARING EXTENDER			QTY 1	
UNLESS OTHERWISE SPECIFIED DIMENSIONS ARE IN INCHES TOLERANCES ARE: FRACTIONS DECIMALS ANGLES + .01 + 1		CAD GENERATED DRAWING, REPORT ANY CHANGES		8" DOBSONIAN TELESCOPE PROJECT 2004 
		APPROVALS	DATE	
DRAWN	JRR			
CHECKED				
MATERIAL	1/4" PLYWOOD	RESP ENG		
FINISH	--	MFG ENG		
DO NOT SCALE DRAWING		QUAL ENG		
SIZE	A	DWG. NO.		REV.
SCALE	1:2	CAD FILE:		SHEET OF

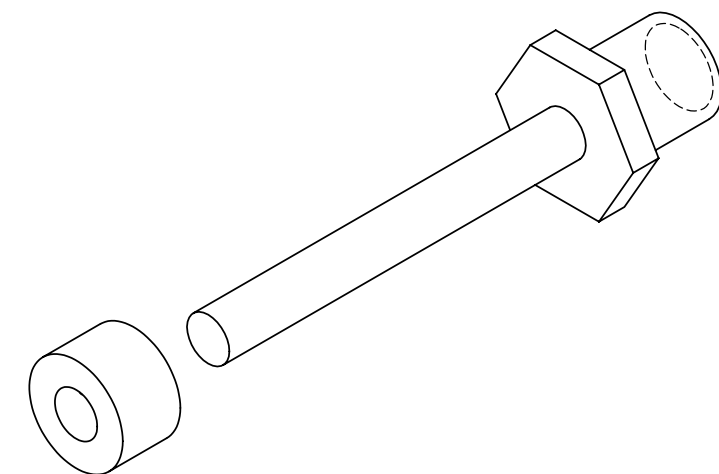
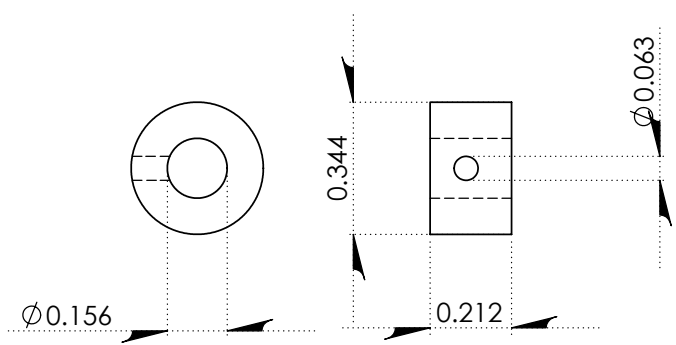
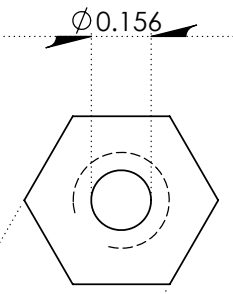
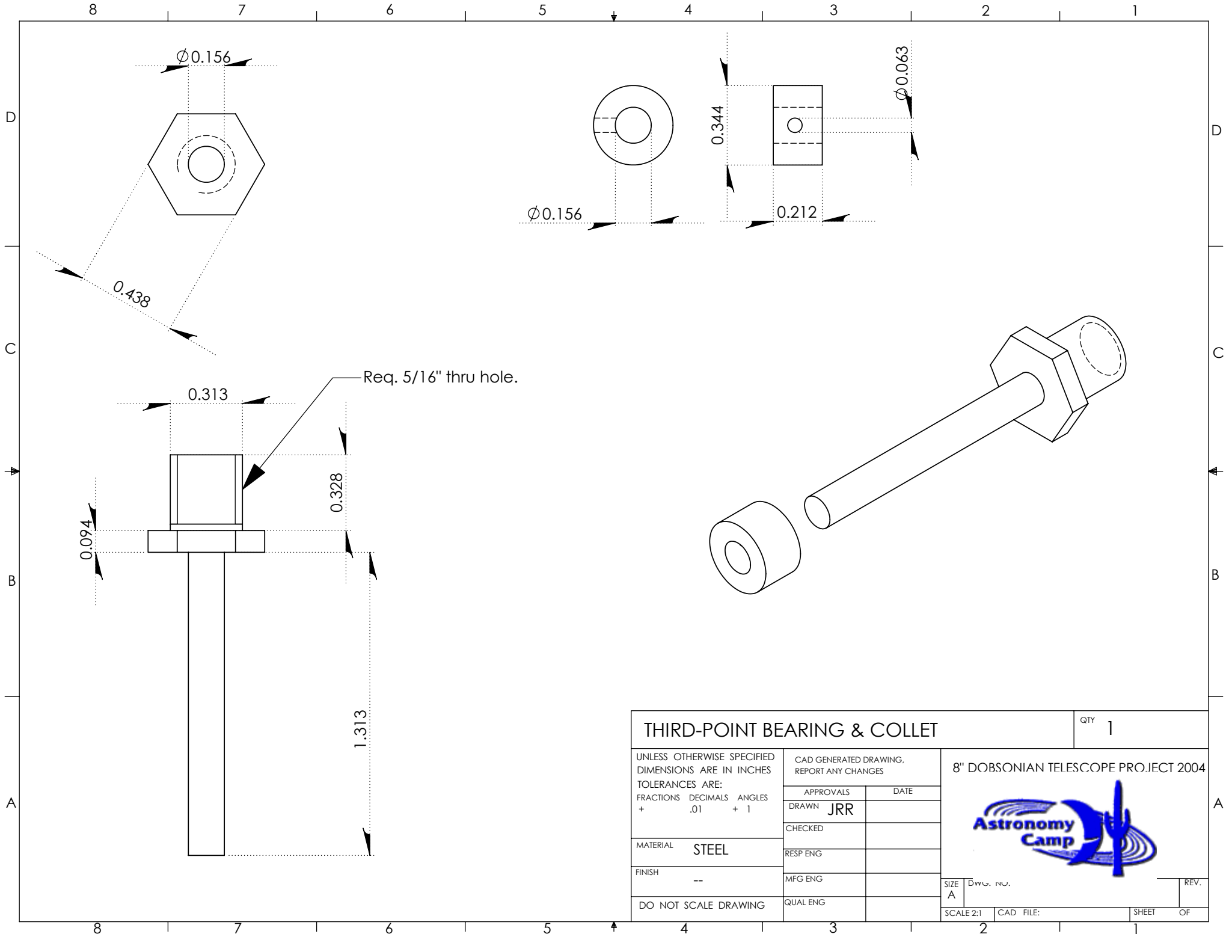

THIRD-POINT BEARING & COLLET			QTY 1		
UNLESS OTHERWISE SPECIFIED DIMENSIONS ARE IN INCHES		CAD GENERATED DRAWING. REPORT ANY CHANGES		8" DOBSONIAN TELESCOPE PROJECT 2004	
TOLERANCES ARE:		APPROVALS			
FRACTIONS	DECIMALS	ANGLES	DRAWN	JRR	
+	.01	+ 1	CHECKED		
MATERIAL	STEEL		RESP ENG		
FINISH	--		MFG ENG		
DO NOT SCALE DRAWING			QUAL ENG		
SIZE A	DWG. NO.				REV.
SCALE 2:1	CAD FILE:				SHEET OF



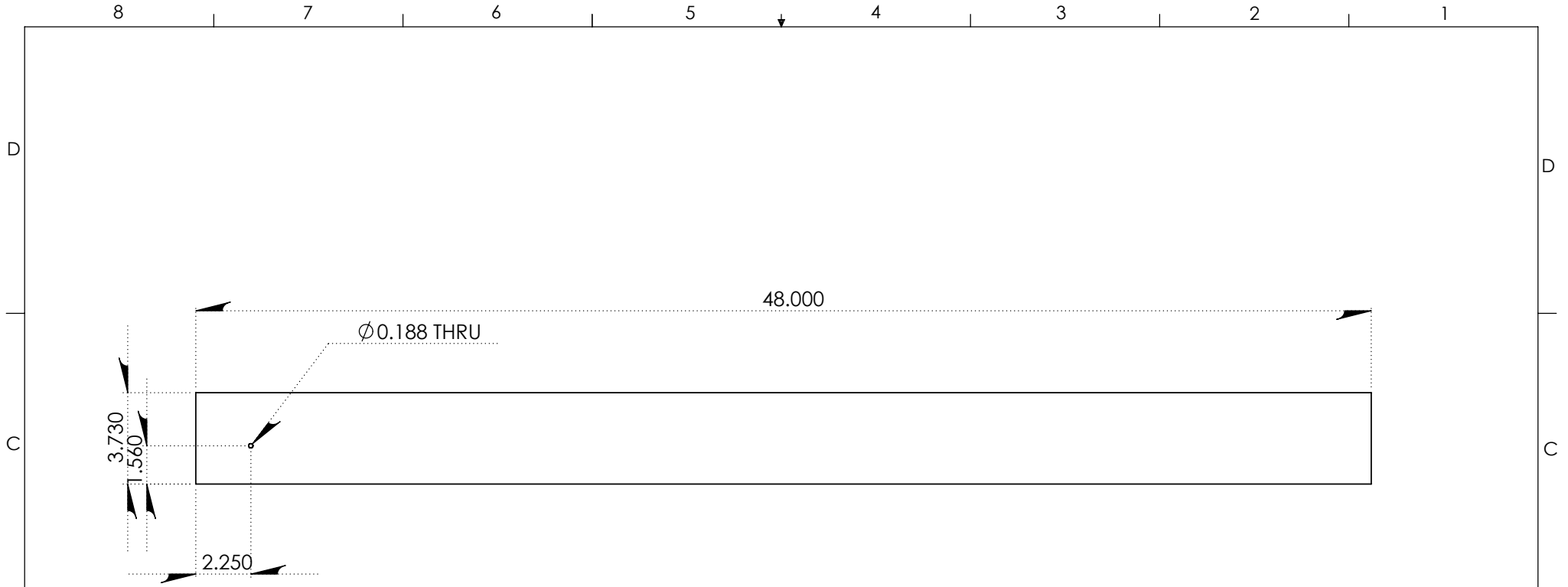

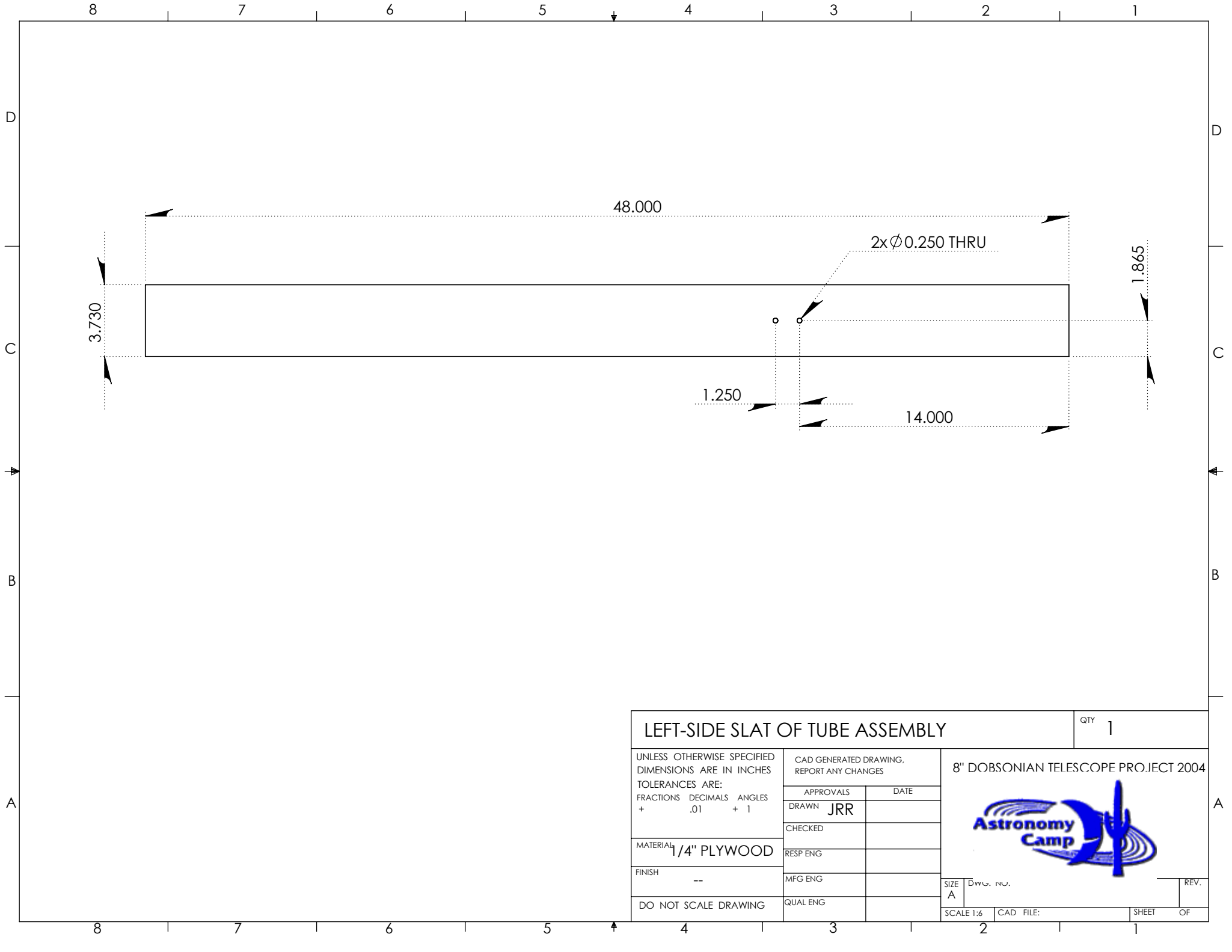

NOTE: This pair of slats should be symmetrical around the telescope optical axis. The side shown here will be outside on the left side of the telescope, and on the inside on the right side. Paint and install accordingly.

SLAT WITH SPIDER ATTACHMENT HOLE			QTY 2		
UNLESS OTHERWISE SPECIFIED DIMENSIONS ARE IN INCHES TOLERANCES ARE: FRACTIONS DECIMALS ANGLES + .01 + 1	CAD GENERATED DRAWING. REPORT ANY CHANGES		8" DOBSONIAN TELESCOPE PROJECT 2004 		
	APPROVALS	DATE			
	DRAWN JRR				
	CHECKED				
	RESP ENG				
MATERIAL 1/4" PLYWOOD	MFG ENG		SIZE A	DWG. NO.	
FINISH --	QUAL ENG		SCALE 1:6	CAD FILE:	
DO NOT SCALE DRAWING			SHEET	OF	

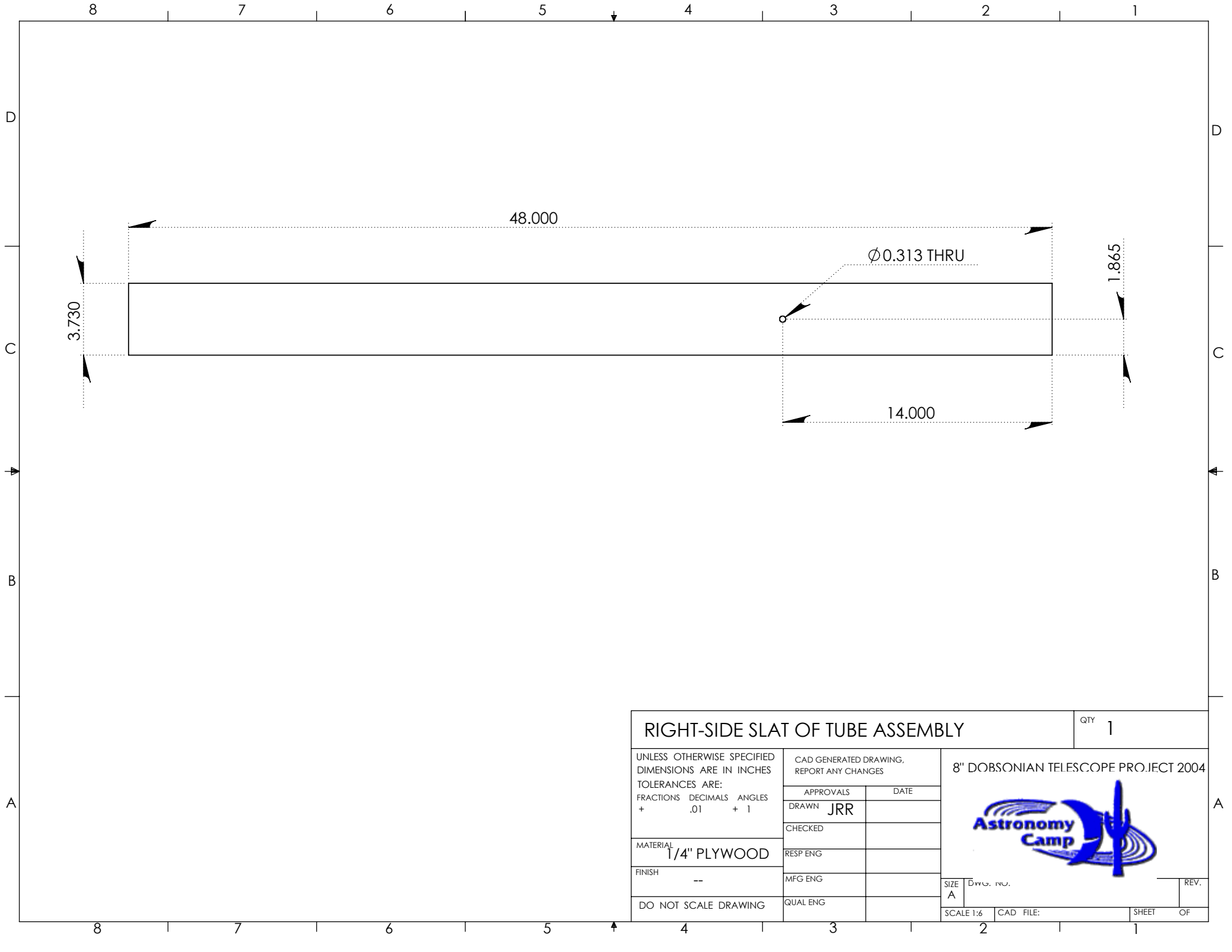

LEFT-SIDE SLAT OF TUBE ASSEMBLY				QTY 1							
UNLESS OTHERWISE SPECIFIED DIMENSIONS ARE IN INCHES TOLERANCES ARE: FRACTIONS DECIMALS ANGLES + .01 + 1		CAD GENERATED DRAWING. REPORT ANY CHANGES		8" DOBSONIAN TELESCOPE PROJECT 2004 							
		APPROVALS	DATE								
MATERIAL 1/4" PLYWOOD		DRAWN JRR		<table border="1"> <tr> <td>SIZE A</td> <td>DWG. NO.</td> <td>REV.</td> </tr> <tr> <td>SCALE 1:6</td> <td>CAD FILE:</td> <td>SHEET OF</td> </tr> </table>		SIZE A	DWG. NO.	REV.	SCALE 1:6	CAD FILE:	SHEET OF
SIZE A	DWG. NO.	REV.									
SCALE 1:6	CAD FILE:	SHEET OF									
FINISH --		CHECKED									
DO NOT SCALE DRAWING		RESP ENG									
		MFG ENG									
		QUAL ENG									



RIGHT-SIDE SLAT OF TUBE ASSEMBLY			QTY 1		
UNLESS OTHERWISE SPECIFIED DIMENSIONS ARE IN INCHES		CAD GENERATED DRAWING. REPORT ANY CHANGES		8" DOBSONIAN TELESCOPE PROJECT 2004 	
TOLERANCES ARE:		APPROVALS	DATE		
FRACTIONS	DECIMALS	ANGLES			
+	.01	+ 1			
MATERIAL 1/4" PLYWOOD		DRAWN	JRR		
FINISH		CHECKED			
		RESP ENG			
		MFG ENG			
DO NOT SCALE DRAWING		QUAL ENG		SIZE A	DWG. NO.
		SCALE 1:6		CAD FILE:	REV.
		SHEET		OF	