

8 7 6 5 4 3 2 1

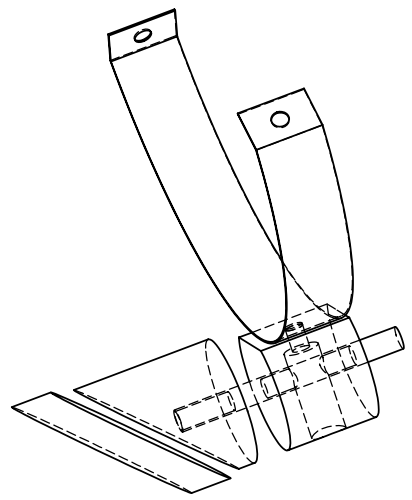

NOTES

- 1. Vane secured with 8-32 x 1/2" screw; nut epoxied inside hub.
- 2. Threaded rod, 1/4-20 x 3, with washer and wingnut on front side of hub.
- 3. Use #8-32 x 1/2" screws to attach to telescope tube, washers inside & out.

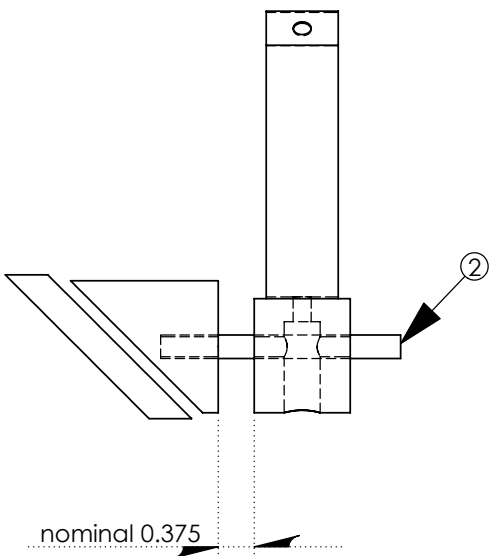
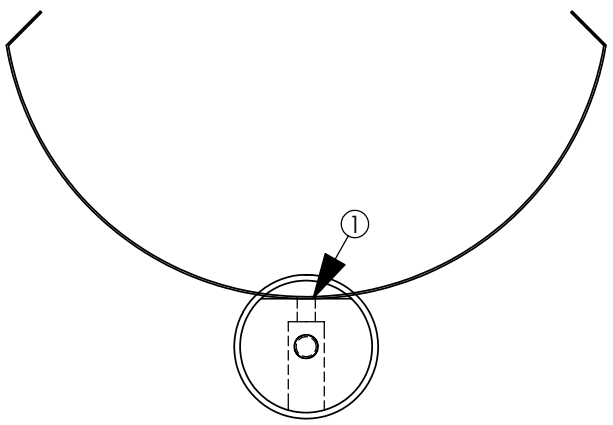
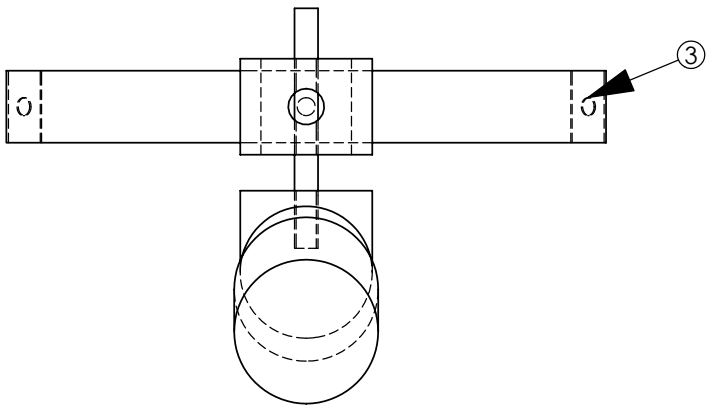

SPIDER ASSEMBLY

QTY 1

UNLESS OTHERWISE SPECIFIED DIMENSIONS ARE IN INCHES		CAD GENERATED DRAWING, REPORT ANY CHANGES		8" DOBSONIAN TELESCOPE PROJECT 2004	
TOLERANCES ARE:		APPROVALS		DATE	
FRACTIONS	DECIMALS	DRAWN JRR			
+	.01	CHECKED			
ANGLES		RESP ENG			
+ 1		MFG ENG			
MATERIAL --		QUAL ENG		SIZE : DWG. NO.	
FINISH --				A	
DO NOT SCALE DRAWING				SCALE 1:2 CAD FILE:	
				REV.	
				SHEET OF	



D
C
B
A

D
C
B
A

8 7 6 5 4 3 2 1

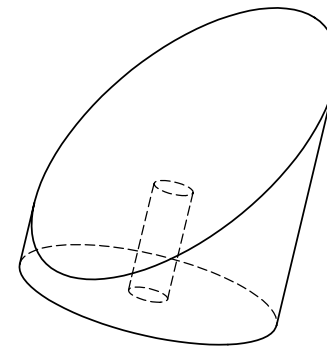
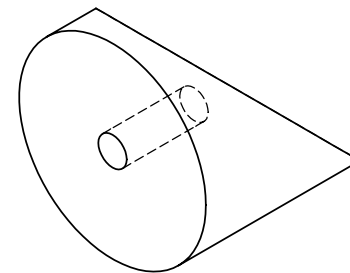
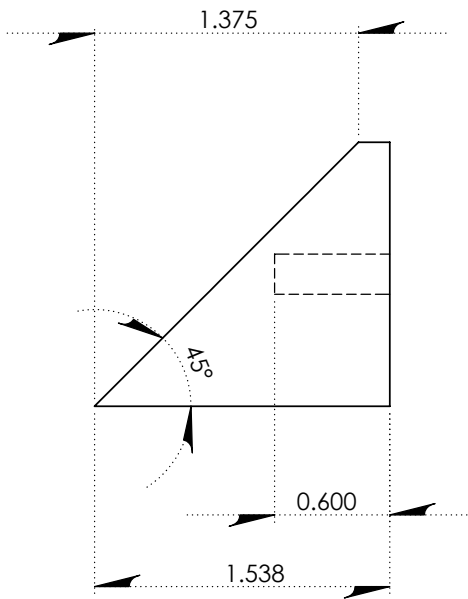
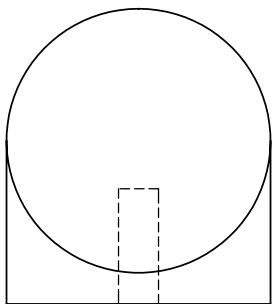
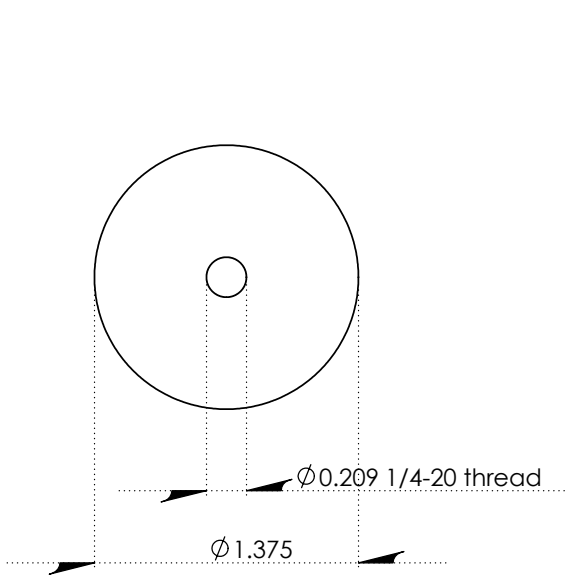

SECONDARY MIRROR HOLDER

QTY 1

UNLESS OTHERWISE SPECIFIED
DIMENSIONS ARE IN INCHES

TOLERANCES ARE:
FRACTIONS DECIMALS ANGLES
+ .01 + 1

MATERIAL WOOD

FINISH --

DO NOT SCALE DRAWING

CAD GENERATED DRAWING.
REPORT ANY CHANGES

APPROVALS DATE

DRAWN JRR

CHECKED

RESP ENG

MFG ENG

QUAL ENG

8" DOBSONIAN TELESCOPE PROJECT 2004





SIZE : DWG. NO.
A

REV.

SCALE 1:1 CAD FILE:

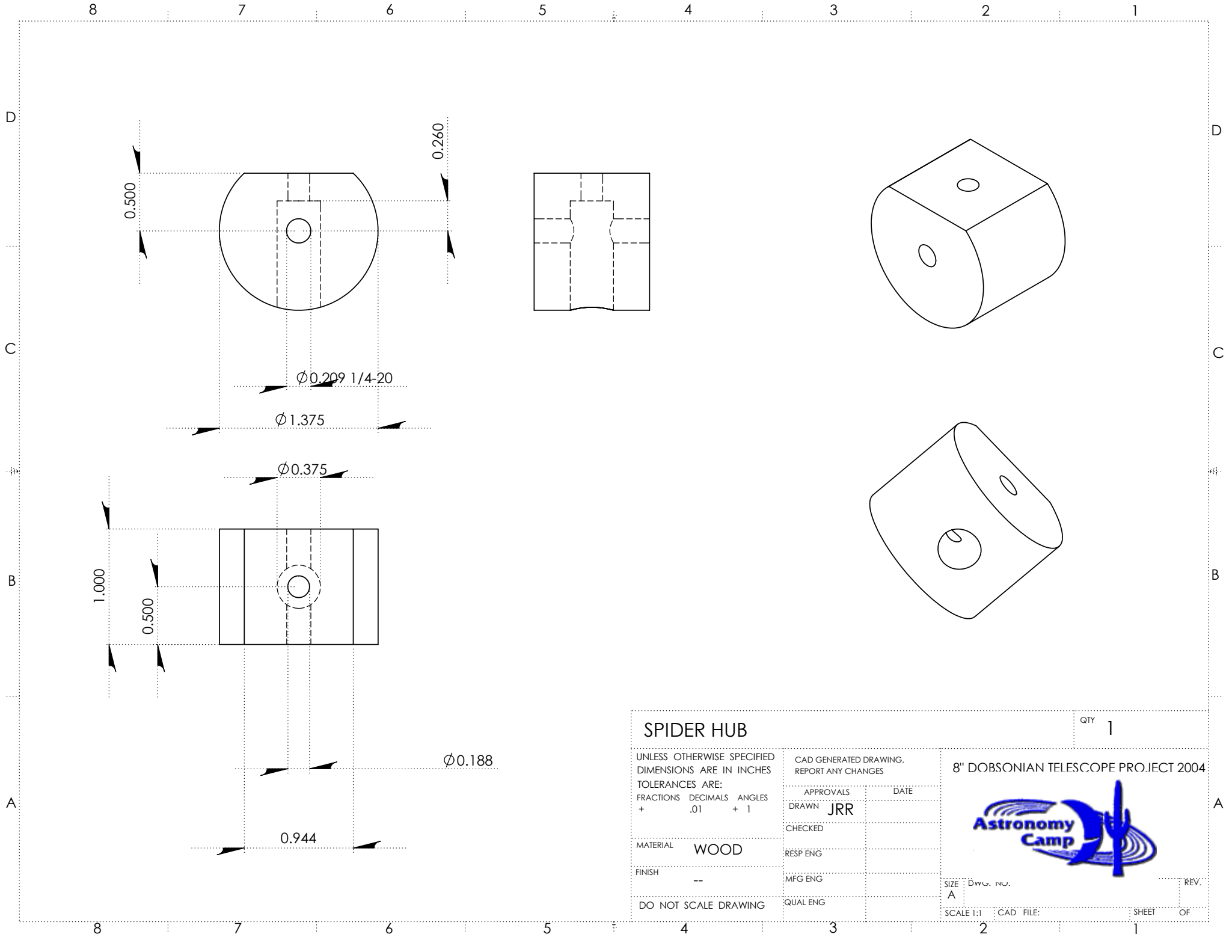
SHEET OF



SPIDER HUB		QTY 1
UNLESS OTHERWISE SPECIFIED DIMENSIONS ARE IN INCHES TOLERANCES ARE: FRACTIONS DECIMALS ANGLES + .01 + 1		CAD GENERATED DRAWING. REPORT ANY CHANGES
APPROVALS		DATE
DRAWN JRR		
CHECKED		
RESP ENG		
MATERIAL WOOD		
FINISH --		
DO NOT SCALE DRAWING		
		8" DOBSONIAN TELESCOPE PROJECT 2004
		
		SIZE : DWG. NO. REV.
		A
		SCALE 1:1 CAD FILE: SHEET OF

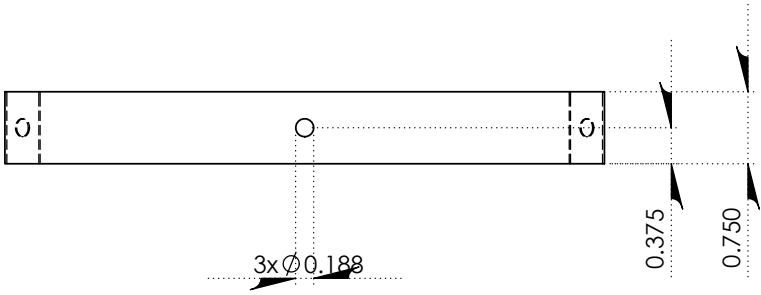
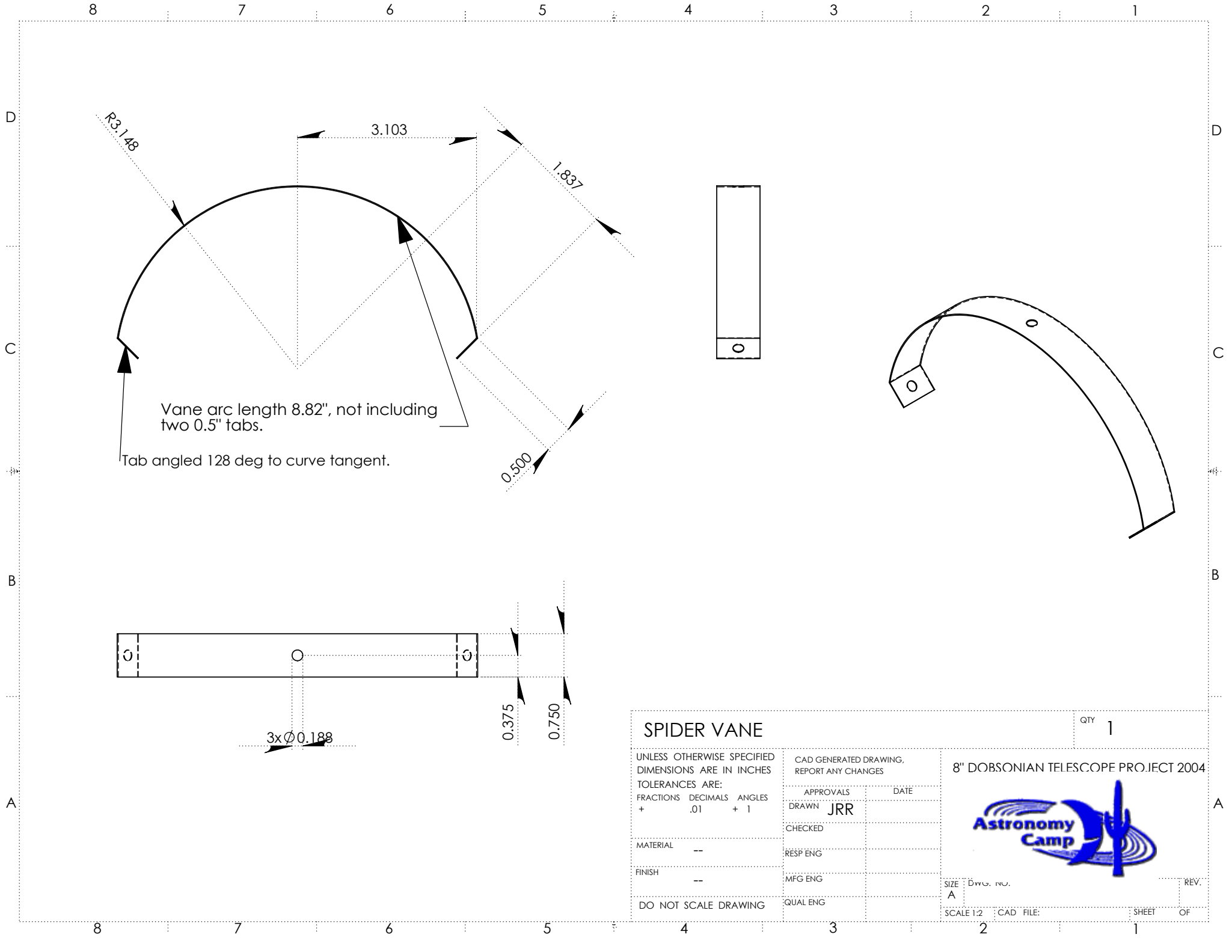

SPIDER VANE			QTY	1
UNLESS OTHERWISE SPECIFIED DIMENSIONS ARE IN INCHES		CAD GENERATED DRAWING. REPORT ANY CHANGES		8" DOBSONIAN TELESCOPE PROJECT 2004
TOLERANCES ARE:		APPROVALS	DATE	
FRACTIONS	DECIMALS	ANGLES		
+	.01	+ 1	DRAWN JRR	
			CHECKED	
MATERIAL	--		RESP ENG	
FINISH	--		MFG ENG	
DO NOT SCALE DRAWING			QUAL ENG	
SIZE : DWG. NO.		REV.		
A				
SCALE 1:2		CAD FILE:		SHEET OF
				1

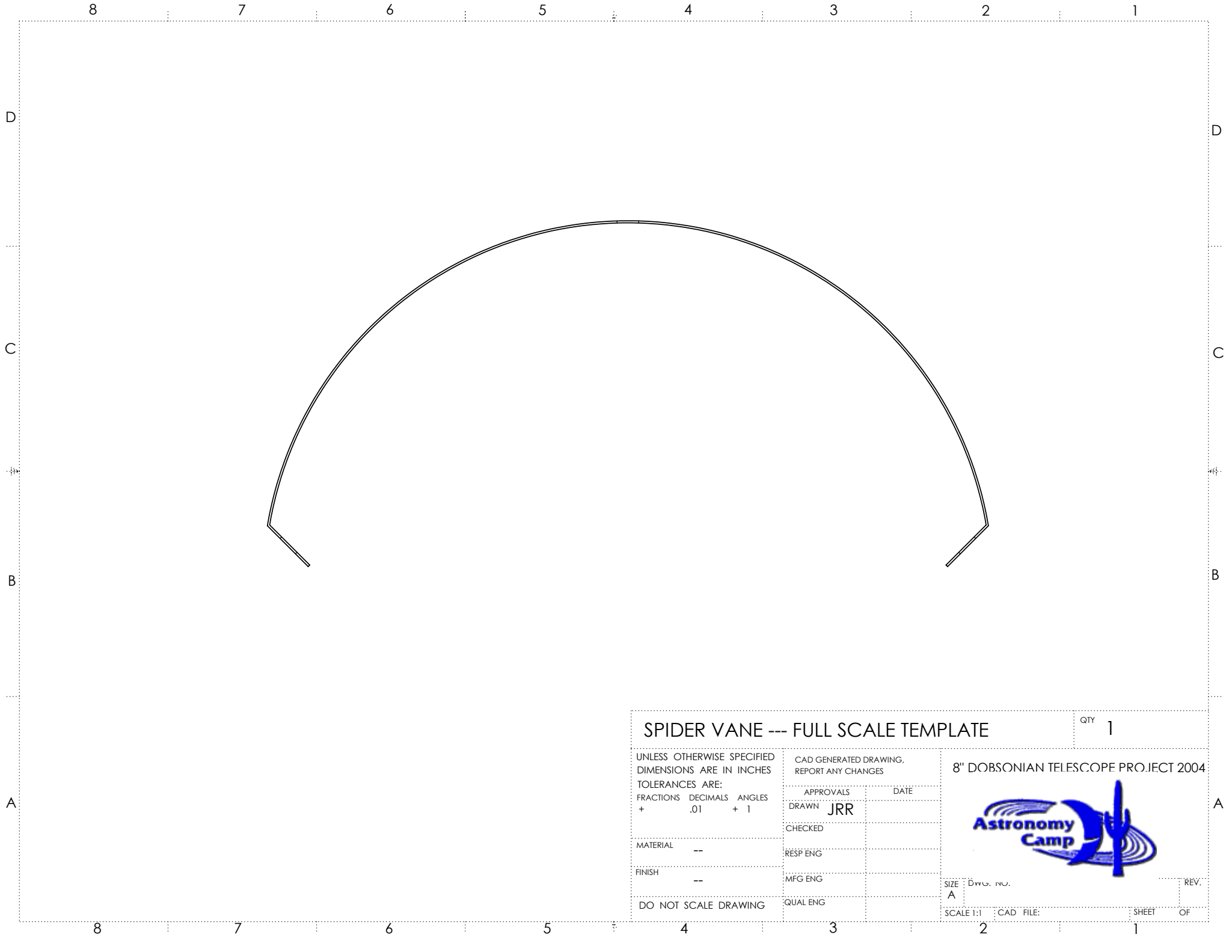

<p>SPIDER VANE --- FULL SCALE TEMPLATE</p>			<p>QTY 1</p>
<p>UNLESS OTHERWISE SPECIFIED DIMENSIONS ARE IN INCHES</p>		<p>CAD GENERATED DRAWING. REPORT ANY CHANGES</p>	
<p>TOLERANCES ARE:</p>		<p>8" DOBSONIAN TELESCOPE PROJECT 2004</p>	
<p>FRACTIONS</p>	<p>DECIMALS</p>	<p>APPROVALS</p>	<p>DATE</p>
<p>+</p>	<p>.01</p>	<p>DRAWN JRR</p>	
<p>ANGLES</p>	<p>+ 1</p>	<p>CHECKED</p>	
<p>MATERIAL</p>	<p>--</p>	<p>RESP ENG</p>	
<p>FINISH</p>	<p>--</p>	<p>MFG ENG</p>	
<p>DO NOT SCALE DRAWING</p>	<p>QUAL ENG</p>	<p>SIZE : DWG. NO.</p>	<p>REV.</p>
		<p>A</p>	
		<p>SCALE 1:1</p>	<p>CAD FILE:</p>
		<p>SHEET</p>	<p>OF</p>

